

Review Problems for the Final

These problems are provided to help you study. The presence of a problem on this handout does not imply that there *will* be a similar problem on the test. And the absence of a topic does not imply that it *won't* appear on the test.

1. Find the remaining sides and angle in the following triangle:

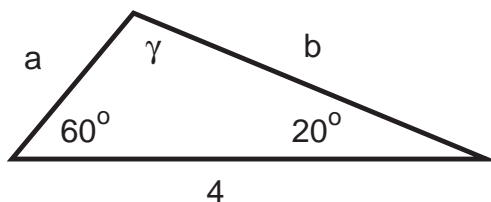

2. Find the third side of the following triangle:

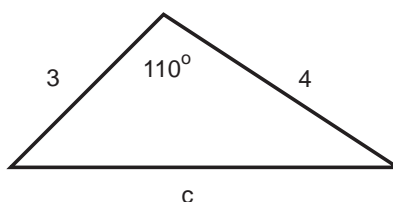

3. For the function $y = -5 + 4 \cos(3x - 6)$, find:

- (a) The amplitude.
- (b) The y -coordinate of the highest points on the graph.
- (c) The period.
- (d) The phase shift.
- (e) The x -coordinate of the first minimum to the right of the origin.

All your answers should be *exact*, rather than approximate. Or else.

4. Find a function of the form $y = A + B \sin k(x - c)$ which has the graph shown below.

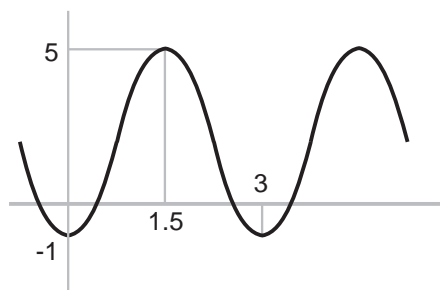

5. Solve the right triangle, finding the angles in degrees to at least 3 decimal places.

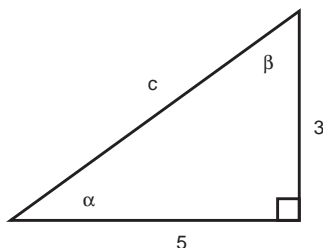

6. Find all solutions to $(\sin x)^2 = \frac{1}{16}$ in the interval $0 \leq x \leq 2\pi$. Express your solutions in radians to at least 2 decimal places.

7. Calvin is 40 feet from a tree, which subtends an angle of 25° at ground level where he is standing. Phoebe stands on the opposite side of the tree, which subtends an angle of 35° at ground level where she is standing. How far is Phoebe from the tree?

8. Find all solutions to $2 \sin 2x + 1 = 0$ for $0 \leq x \leq 2\pi$. Express your answers in exact radians.

9. Find all solutions to $2(\sin \theta)^3 + 3(\sin \theta)^2 + \sin \theta = 0$ for $0^\circ \leq \theta < 360^\circ$. Just for fun, express your answers in exact degrees.

10. (a) If $\tan \theta = \frac{24}{7}$, what are the possible values for $\sin \theta$? What are the possible values for $\cos 2\theta$?

(b) θ is an angle in the second quadrant and $\sin \theta = \frac{6}{7}$. Find θ in radians to at least 5 decimal places.

11. Prove the identity

$$(\sec x)^2 (\csc x)^2 = (\sec x)^2 + (\csc x)^2.$$

12. (a) Find the exact value of $\tan 735^\circ$, whether you like it or not.

(b) Find the exact value of $\cos \frac{\pi}{12}$.

13. Solve the right triangle, finding the angles in radians to at least 3 decimal places.

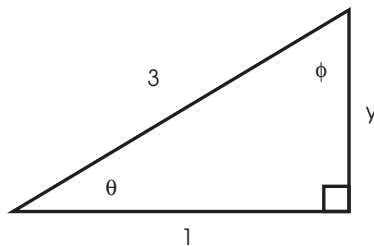

14. (a) Do your darndest to express 735° in exact radians.

(b) Express $\frac{-17\pi}{12}$ in exact degrees.

15. A hula hoop (“hula hoop”?!) 12 miles in diameter makes 3 revolutions per second. Calvin Butterball ties his cat Fido to the edge.

(a) What is Fido’s *angular* velocity?

(b) What is Fido’s *linear* velocity?

16. (a) Phoebe can buy a 45° -slice out of a pepperoni pizza 12 feet in diameter or a $\frac{\pi}{6}$ -radian slice out of a pepperoni pizza whose radius is 8 feet. On the principle that heart attacks are things that happen to other people, Phoebe is determined to buy the largest slice possible. Which one should she buy?

(b) A 60° -wedge is cut out of an apple pie 24 yards in diameter. What is the length of the crust?

17. Compute the values of all six trigonometric functions for the angle θ shown below.

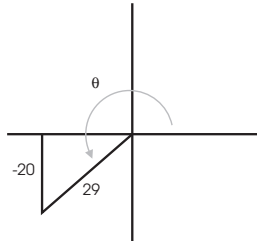

18. Find all solutions in approximate radians to 5 decimal places between 0 and 2π to the equation $\cos 3x = 0.1$.

Solutions to the Review Problems for the Final

1. Find the remaining sides and angle in the following triangle:

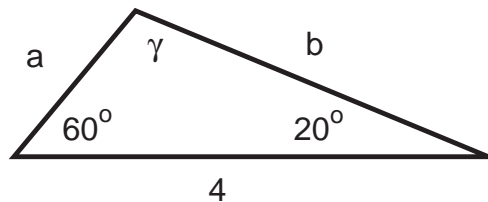

$$\gamma = 180^\circ - 60^\circ - 20^\circ = 100^\circ.$$

By the Law of Sines,

$$\frac{a}{\sin 20^\circ} = \frac{4}{\sin 100^\circ}, \quad a = \frac{4 \sin 20^\circ}{\sin 100^\circ} \approx 1.38919,$$

$$\frac{b}{\sin 60^\circ} = \frac{4}{\sin 100^\circ}, \quad b = \frac{4 \sin 60^\circ}{\sin 100^\circ} \approx 3.51754. \quad \square$$

2. Find the third side of the following triangle:

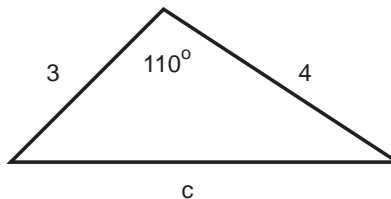

Apply the Law of Cosines:

$$c^2 = 3^2 + 4^2 - 2(3)(4) \cos 110^\circ \approx 33.20848, \quad c \approx 5.76268. \quad \square$$

3. For the function $y = -5 + 4 \cos(3x - 6)$, find:

(a) The amplitude.

The amplitude is 4. \square

(b) The y -coordinate of the highest points on the graph.

Since

$$-1 \leq \cos(\text{junk}) \leq 1, \quad -4 \leq 4 \cos(\text{junk}) \leq 4, \quad \text{so} \quad -9 \leq -5 + 4 \cos(\text{junk}) \leq -1.$$

The highest points on the graph are at $y = -1$. \square

(c) The period.

The period is $\frac{2\pi}{3}$. \square

(d) The phase shift.

Write the equation as $y = -5 + 4 \cos 3(x - 2)$. The phase shift is 2 units to the right. \square

(e) The x -coordinate of the first minimum to the right of the origin.

Look at the mins near the origin for an *unshifted* period $\frac{2\pi}{3}$ cosine curve:

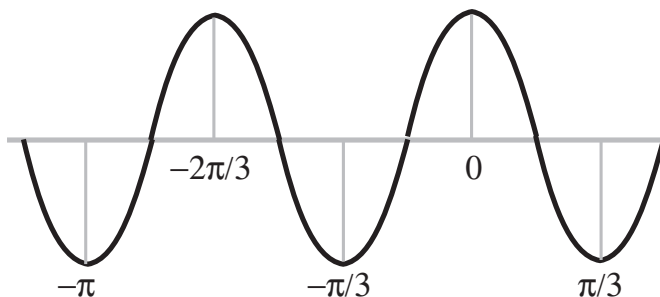

The given curve is shifted 2 units to the right, so it has mins at

$$-\pi + 2 \approx -1.14159, \quad -\frac{\pi}{3} + 2 \approx 0.95280, \quad \frac{\pi}{3} + 2 \approx 3.04720.$$

The first minimum to the right of the origin is at $x = -\frac{\pi}{3} + 2 \approx 0.95280$. \square

4. Find a function of the form $y = A + B \sin k(x - c)$ which has the graph shown below.

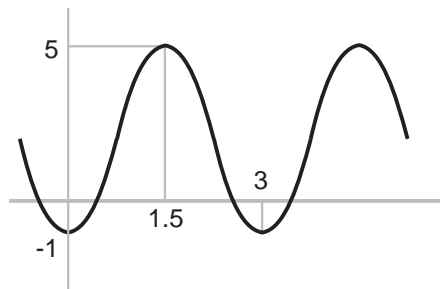

The amplitude is $\frac{5 - (-1)}{2} = 3$.

The vertical translation is 2 units upward.

The distance between a max and a min is $3 - 1.5 = 1.5$. Therefore, the period is $2 \cdot 1.5 = 3$. The multiplier is $k = \frac{2\pi}{3}$.

An unshifted period 3 sine curve has its first max at one-quarter of a cycle, or $\frac{3}{4} = 0.75$. This curve has a max at $x = 1.5$, so the phase shift is 0.75 units to the right.

A function with the given graph is $y = 2 + 3 \sin \frac{2\pi}{3}(x - 0.75)$. \square

5. Solve the right triangle, finding the angles in degrees to at least 3 decimal places.

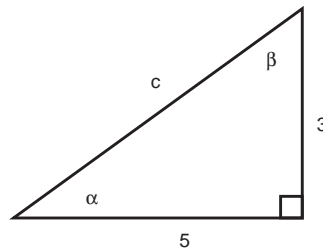

$$c = \sqrt{3^2 + 5^2} = \sqrt{34} \approx 5.83095.$$

$$\alpha = \tan^{-1} \frac{3}{5} \approx 30.96376^\circ.$$

$$\beta = 190^\circ - 90^\circ - \alpha \approx 59.03624^\circ. \quad \square$$

6. Find all solutions to $(\sin x)^2 = \frac{1}{16}$ in the interval $0 \leq x \leq 2\pi$. Express your solutions in radians to at least 2 decimal places.

$(\sin x)^2 = \frac{1}{16}$ gives $\sin x = \pm \frac{1}{4}$. I begin by finding the first quadrant solution $\theta = \sin^{-1} \frac{1}{4}$.

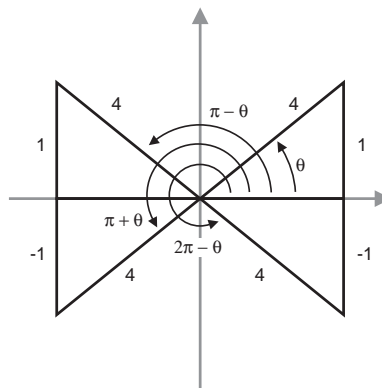

As the picture shows, the other solutions will be

$$\pi - \theta, \quad \pi + \theta, \quad 2\pi - \theta.$$

Thus, the solutions are

$$\theta = \sin^{-1} \frac{1}{4} \approx 0.25268, \quad \pi - \theta \approx 2.88891, \quad \pi + \theta \approx 3.39427, \quad 2\pi - \theta \approx 6.03051. \quad \square$$

7. Calvin is 40 feet from a tree, which subtends an angle of 25° at ground level where he is standing. Phoebe stands on the opposite side of the tree, which subtends an angle of 35° at ground level where she is standing. How far is Phoebe from the tree?

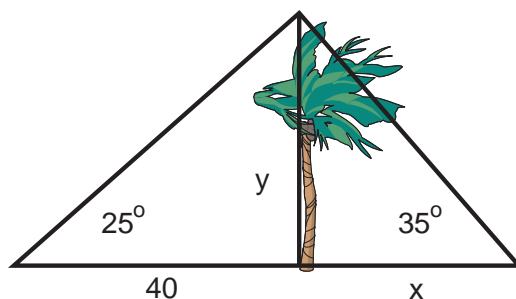

$$\tan 25^\circ = \frac{y}{40}, \quad y = 40 \tan 25^\circ.$$

$$\tan 35^\circ = \frac{y}{x}, \quad x = \frac{y}{\tan 35^\circ} = \frac{40 \tan 25^\circ}{\tan 35^\circ} \approx 26.63825 \text{ feet.} \quad \square$$

8. Find all solutions to $2 \sin 2x + 1 = 0$ for $0 \leq x \leq 2\pi$. Express your answers in exact radians.

Rewrite the equation as $\sin 2x = -\frac{1}{2}$. I'll start by solving $\sin \theta = -\frac{1}{2}$:

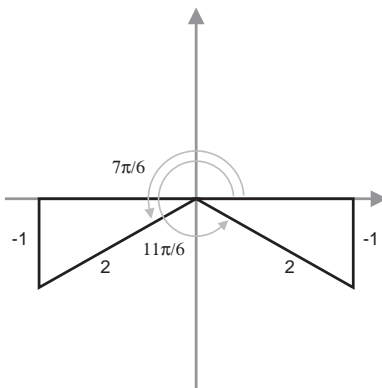

$$\sin \frac{7\pi}{6} = -\frac{1}{2} \quad \text{and} \quad \sin \frac{11\pi}{6} = -\frac{1}{2}.$$

Since the original equation involved $\sin 2x$, I need solutions in the first 2 periods. I get additional solutions by adding multiples of 2π to these base angles:

$$\sin \frac{19\pi}{6} = -\frac{1}{2} \quad \text{and} \quad \sin \frac{23\pi}{6} = -\frac{1}{2}.$$

(If I add additional multiples of 2π , when I solve for x the solutions will be outside the interval $0 \leq x \leq 2\pi$.)

Set $2x$ equal to each of the four angles and solve for x :

$$2x = \frac{7\pi}{6}, \quad x = \frac{7\pi}{12},$$

$$2x = \frac{11\pi}{6}, \quad x = \frac{11\pi}{12},$$

$$2x = \frac{19\pi}{6}, \quad x = \frac{19\pi}{12},$$

$$2x = \frac{23\pi}{6}, \quad x = \frac{23\pi}{12}. \quad \square$$

9. Find all solutions to $2(\sin \theta)^3 + 3(\sin \theta)^2 + \sin \theta = 0$ for $0^\circ \leq \theta < 360^\circ$. Just for fun, express your answers in exact degrees.

Factor:

$$(\sin \theta)(2 \sin \theta + 1)(\sin \theta + 1) = 0.$$

$\sin \theta = 0$ has solutions $\theta = 0^\circ$ and $\theta = 180^\circ$.

$\sin \theta + 1 = 0$ gives $\sin \theta = -1$, which has the solution $\theta = 270^\circ$.

The easiest way to see these four solutions is to draw the graph of the sine function:

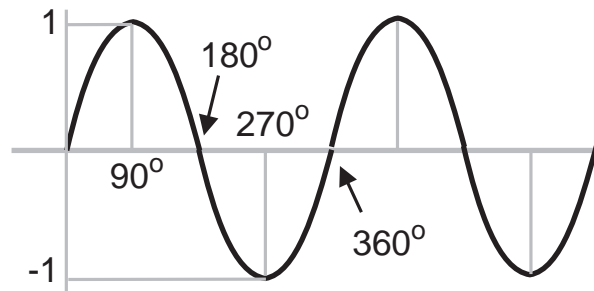

Finally, $2 \sin \theta + 1 = 0$ gives $\sin \theta = -\frac{1}{2}$. The solutions are $\theta = 210^\circ$ and 330° :

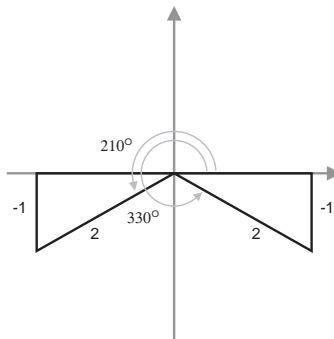

All together, the solutions are

$$0^\circ, \quad 180^\circ, \quad 210^\circ, \quad 270^\circ, \quad 330^\circ. \quad \square$$

10. (a) If $\tan \theta = \frac{24}{7}$, what are the possible values for $\sin \theta$? What are the possible values for $\cos 2\theta$?

There are two angles in the interval $0 \leq \theta \leq 2\pi$ which have $\tan \theta = \frac{24}{7}$:

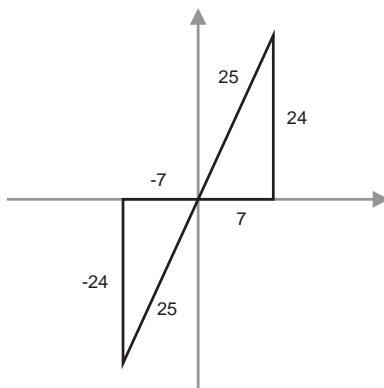

In each case, the hypotenuse of the triangle is

$$\sqrt{7^2 + 24^2} = \sqrt{625} = 25.$$

For the first quadrant angle, $\sin \theta = \frac{24}{25}$.

For the third quadrant angle, $\sin \theta = -\frac{24}{25}$.

In either case, the double angle formula for cosine gives

$$\cos 2\theta = 1 - 2(\sin \theta)^2 = 1 - 2\left(\pm \frac{24}{25}\right)^2 = -\frac{527}{625}. \quad \square$$

- (b) θ is an angle in the second quadrant and $\sin \theta = \frac{6}{7}$. Find θ in radians to at least 5 decimal places.

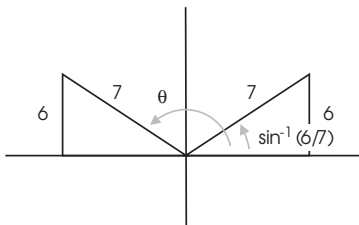

It *isn't* true that $\theta = \sin^{-1} \frac{6}{7}$, because θ is not between $-\frac{\pi}{2}$ and $\frac{\pi}{2}$. Instead, I see from the picture that

$$\theta = \pi - \sin^{-1} \frac{6}{7} \approx 2.11190. \quad \square$$

11. Prove the identity

$$(\sec x)^2(\csc x)^2 = (\sec x)^2 + (\csc x)^2.$$

$$(\sec x)^2(\csc x)^2 = \left(\frac{1}{\cos x}\right)^2 \left(\frac{1}{\sin x}\right)^2 = \frac{1}{(\cos x)^2(\sin x)^2} = \frac{(\sin x)^2 + (\cos x)^2}{(\cos x)^2(\sin x)^2} =$$

$$\frac{(\sin x)^2}{(\cos x)^2(\sin x)^2} + \frac{(\cos x)^2}{(\cos x)^2(\sin x)^2} = \frac{1}{(\cos x)^2} + \frac{1}{(\sin x)^2} = (\sec x)^2 + (\csc x)^2. \quad \square$$

12. (a) Find the exact value of $\tan 735^\circ$, whether you like it or not.

First, $735^\circ = 15^\circ + 4 \cdot 180^\circ$. Since the tangent function is periodic with period 180° , $\tan 735^\circ = \tan 15^\circ$.
Next, I'll use

$$\tan(a + b) = \frac{\tan a + \tan b}{1 - \tan a \tan b}.$$

Take $a = 45^\circ$ and $b = -30^\circ$. Then

$$\tan 15^\circ = \frac{\tan 45^\circ + \tan(-30^\circ)}{1 - \tan 45^\circ \tan(-30^\circ)} = \frac{1 - \frac{1}{\sqrt{3}}}{1 + \frac{1}{\sqrt{3}}} = \frac{\sqrt{3} - 1}{\sqrt{3} + 1}. \quad \square$$

(b) Find the exact value of $\cos \frac{\pi}{12}$.

I'll use the double angle formula

$$(\cos \theta)^2 = \frac{1}{2}(1 + \cos 2\theta).$$

I get

$$\left(\cos \frac{\pi}{12}\right)^2 = \frac{1}{2}\left(1 + \cos \frac{\pi}{6}\right) = \frac{1}{2}\left(1 + \frac{\sqrt{3}}{2}\right).$$

Since $\cos \frac{\pi}{12} > 0$, I get

$$\cos \frac{\pi}{12} = \sqrt{\frac{1}{2}\left(1 + \frac{\sqrt{3}}{2}\right)}. \quad \square$$

13. Solve the right triangle, finding the angles in radians to at least 3 decimal places.

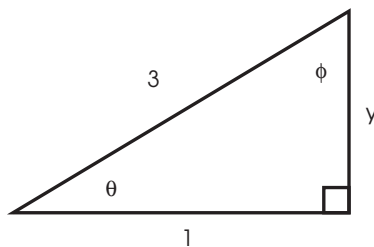

$$y = \sqrt{3^2 - 1^2} = 2\sqrt{2}.$$

$$\theta = \cos^{-1} \frac{1}{3} \approx 1.23096.$$

$$\phi = \frac{\pi}{2} - \theta \approx 0.33984. \quad \square$$

14. (a) Do your darndest to express 735° in exact radians.

$$735^\circ = 735 \text{ deg} \cdot \frac{\pi \text{ rad}}{180 \text{ deg}} = \frac{49\pi}{12} \text{ radians. } \square$$

(b) Express $\frac{-17\pi}{12}$ in exact degrees.

$$\frac{-17\pi}{12} \text{ rad} = \frac{-17\pi}{12} \text{ rad} \cdot \frac{180 \text{ deg}}{\pi \text{ rad}} = -255^\circ. \quad \square$$

15. A hula hoop (“hula hoop”?!) 12 miles in diameter makes 3 revolutions per second. Calvin Butterball ties his cat Fido to the edge.

(a) What is Fido’s *angular* velocity?

You need to convert revolutions per second to radians per second:

$$\omega = 3 \frac{\text{rev}}{\text{sec}} = 3 \frac{\text{rev}}{\text{sec}} \cdot \frac{2\pi \text{ rad}}{1 \text{ rev}} = 6\pi \text{ radianspersecond. } \square$$

(b) What is Fido’s *linear* velocity?

The radius is $\frac{12}{2} = 6$, so Fido’s linear velocity is

$$v = \omega r = 36\pi \text{ milespersecond. } \square$$

16. (a) Phoebe can buy a 45° -slice out of a pepperoni pizza 12 feet in diameter or a $\frac{\pi}{6}$ -radian slice out of a pepperoni pizza whose radius is 8 feet. On the principle that heart attacks are things that happen to other people, Phoebe is determined to buy the largest slice possible. Which one should she buy?

Since $45^\circ = \frac{\pi}{4}$ radians, the area of the first slice is

$$\frac{1}{2} \cdot 6^2 \cdot \frac{\pi}{4} = \frac{9\pi}{2}.$$

The area of the second slice is

$$\frac{1}{2} \cdot 8^2 \cdot \frac{\pi}{6} = \frac{16\pi}{3}.$$

Since $\frac{16\pi}{3} > \frac{9\pi}{2}$, she should buy the first slice (and some good medical insurance). \square

(b) A 60° -wedge is cut out of an apple pie 24 yards in diameter. What is the length of the crust?

Since $60^\circ = \frac{\pi}{3}$ radians, the length is

$$12 \cdot \frac{\pi}{3} = 4\pi. \quad \square$$

17. Compute the values of all six trigonometric functions for the angle θ shown below.

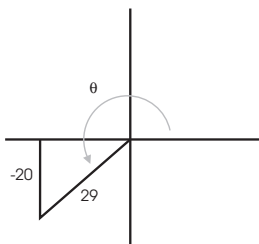

By Pythagoras, $x = -\sqrt{29^2 - 20^2} = -21$. Therefore,

$$\begin{aligned}\sin \theta &= -\frac{20}{29}, & \cos \theta &= -\frac{21}{29}, & \tan \theta &= \frac{20}{21}, \\ \csc \theta &= -\frac{29}{20}, & \sec \theta &= -\frac{29}{21}, & \cot \theta &= \frac{21}{20}. \quad \square\end{aligned}$$

18. Find all solutions in approximate radians to 5 decimal places between 0 and 2π to the equation $\cos 3x = 0.1$.

First, I solve $\cos \theta = 0.1$.

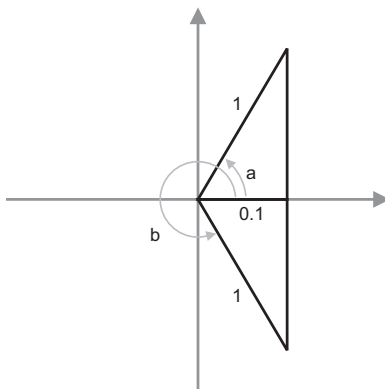

The angle in the first quadrant is $a = \cos^{-1} 0.1$. Since the inverse cosine function only produces angles between 0 and π , I can't use it directly to obtain b . Instead, I notice that b is just $2\pi - a$, so $b = 2\pi - \cos^{-1} 0.1$.

Next, since the original expression was $\cos 3x$, I get solutions in the first three periods by adding 2π to a and b :

$$\begin{aligned}\cos(\cos^{-1} 0.1) &= 0.1, & \cos(2\pi - \cos^{-1} 0.1) &= 0.1, \\ \cos(2\pi + \cos^{-1} 0.1) &= 0.1, & \cos(4\pi - \cos^{-1} 0.1) &= 0.1, \\ \cos(4\pi + \cos^{-1} 0.1) &= 0.1, & \cos(6\pi - \cos^{-1} 0.1) &= 0.1.\end{aligned}$$

Finally, since I want $\cos 3x = 0.1$, I set $3x$ equal to each of the 6 angles above, then solve for x :

$$\begin{aligned}3x &= \cos^{-1} 0.1, & x &= \frac{1}{3} \cos^{-1} 0.1 \approx 0.49021, \\ 3x &= 2\pi - \cos^{-1} 0.1, & x &= \frac{2\pi}{3} - \frac{1}{3} \cos^{-1} 0.1 \approx 1.60419, \\ 3x &= 2\pi + \cos^{-1} 0.1, & x &= \frac{2\pi}{3} + \frac{1}{3} \cos^{-1} 0.1 \approx 2.58460,\end{aligned}$$

$$3x = 4\pi - \cos^{-1} 0.1, \quad x = \frac{4\pi}{3} - \frac{1}{3} \cos^{-1} 0.1 \approx 3.69858,$$

$$3x = 4\pi + \cos^{-1} 0.1, \quad x = \frac{4\pi}{3} + \frac{1}{3} \cos^{-1} 0.1 \approx 4.67900,$$

$$3x = 6\pi - \cos^{-1} 0.1, \quad x = 2\pi - \frac{1}{3} \cos^{-1} 0.1 \approx 5.79298. \quad \square$$

The best thing for being sad is to learn something. - Merlyn, in T.H. WHITE's *The Once and Future King*